

Owner's Manual

- *Installation*
- *Use*
- *Maintenance*

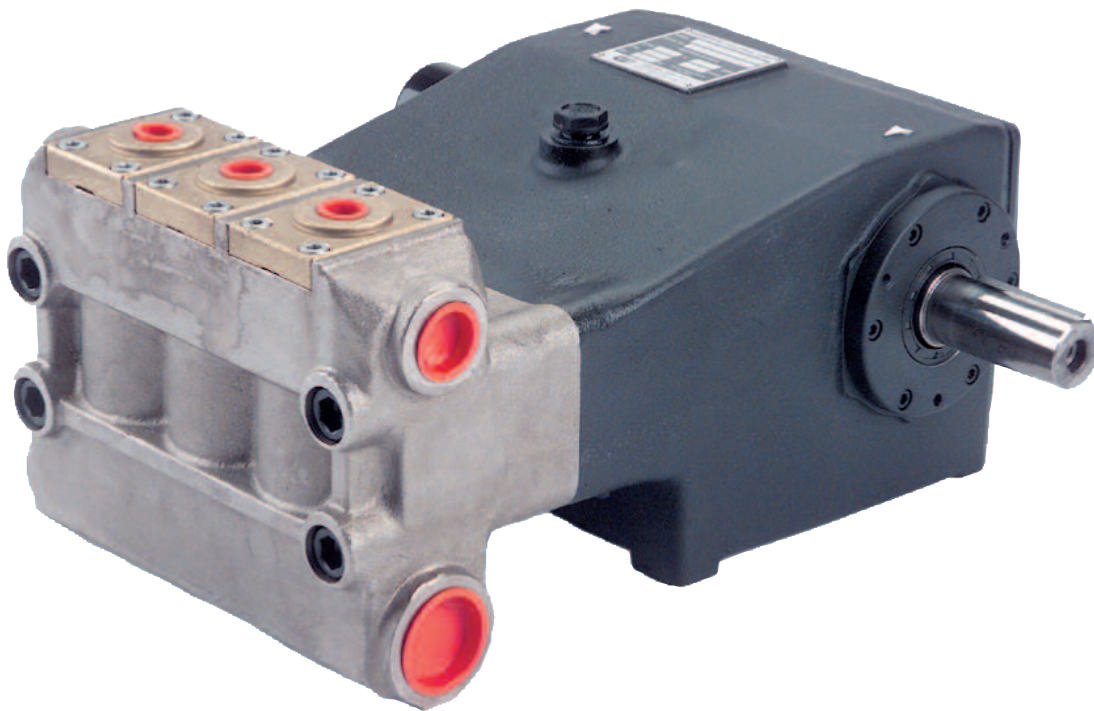

INDEX

1.	INTRODUCTION	Page 3
2.	SYMBOL DESCRIPTIONS	Page 3
3.	SAFETY	Page 3
	3.1 General warnings for safe operation	Page 3
	3.2 High pressure unit safety requirements	Page 3
	3.3 Safety of operation	Page 4
	3.4 General procedures for high pressure lance/gun operation	Page 4
	3.5 Safety of maintenance	Page 4
4.	PUMP IDENTIFICATION	Page 5
5.	TECHNICAL FEATURES	Page 5
6.	DIMENSIONS AND WEIGHT	Page 5
7.	GENERAL INFORMATION ABOUT SPECIFIC PUMP USE	Page 6
	7.1 Water temperature	Page 6
	7.2 Maximum flow and pressure ratings	Page 6
	7.3 Lowest operating RPM	Page 6
8.	CONNECTION AND PLUGS	Page 6
9.	PUMP INSTALLATION	Page 7
	9.1 Positioning	Page 7
	9.2 Direction of rotation	Page 7
	9.3 Water connections	Page 7
	9.4 Suction line	Page 7
	9.5 Filtration	Page 8
	9.6 Delivery time	Page 8
10.	START UP AND RUNNING PROCEDURES	Page 9
	10.1 Before start up	Page 9
	10.2 Starting up	Page 9
	10.3 Water leakage	Page 9
11.	MAINTENANCE INSTRUCTIONS	Page 10
	11.1 Crank mechanism maintenance	Page 10
	11.2 Fluid end maintenance	Page 10
	11.3 Pumping unit maintenance	Page 11
12.	SCREW CALIBRATION	Page 13
13.	MAINTENANCE TOOLS	Page 13
14.	PUMP STOPPED FOR LONG TIME	Page 13
15.	PRECAUTIONS AGAINST FREEZING	Page 13
16.	EXPLODED VIEWS AND PARTS	Page 14
17.	TROUBLE SHOOTING	Page 18

1. INTRODUCTION

KL high pressure water plunger pumps have been designed for long life industrial duties and provided they are correctly installed and maintained will give long trouble-free operation. Read and understand this manual before using your pump; it contains the necessary information for the correct installation, use and maintenance as well as some practical suggestion for trouble shooting.

Upon receipt of your pump, inspect for overall good condition and that no items are missing. Any missing item or damage should be reported before installing and starting the pump.

2. SYMBOL DESCRIPTIONS

**Warning**

Potential Danger

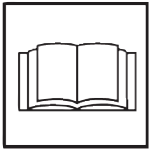

Read carefully and understand the manual before operating the pump

**Danger**

High Voltage

**Danger**

Wear protective mask

**Danger**

Wear goggles

**Danger**

Wear protective gloves

**Danger**

Wear protective boots

3. SAFETY

3.1 General warnings for safe operation

The misuse of a high pressure water unit and the non-observance of the pump installation and maintenance instructions may cause serious damages and/or injuries to people or properties or both.

Any Manufacturer/Operator requested to assemble/use a high pressure water unit should be competent to do so, should have the necessary knowledge on every high pressure component installed in the unit and on the precautions to be taken in order to guarantee the largest safety margins during operation. No precaution, so far as is reasonably practical, should be left out in the interest of safety, both from the Manufacturer and the Operator.

3.2 High pressure unit safety requirements

1. A safety valve should be installed in any delivery line and should be sized to discharge or by-pass the entire pump flow rate
2. High pressure unit components, with particular regard for those units working outside, should be adequately protected against rain, frost and heat.
3. Electric components and wiring should be provided with an adequate degree of protection, able to protect them against spray coming from any direction. They should also be suitable for working in a wet environment.
4. High pressure hoses and any other accessory under pressure should be sized in accordance with the maximum unit working pressure and must always work within the safety margins indicated by the nose/ accessory Manufacturer.
5. High pressure hose ends should be fastened to a steady object in order to prevent them from dangerous sweeping around, should they burst or come off their end fittings.
6. Proper safety guards should be provided to adequately cover transmission joints, pulleys, belts or auxiliary drives.



3.3 Safety of operation

The access into the area when a high pressure unit is working should be strictly prohibited to unauthorized personnel. The area should be suitably enclosed and its perimeter, so far as is reasonably practical, cordoned off and proper warning notices displayed in prominent positions.

Personnel authorized to enter that area should have been previously trained to do so and informed of the risks arising from failures, misuse and any foreseeable circumstance which may occur during operation. Before starting the pump unit and bringing it up to pressure the Operator is requested to carry out the following checks:

1. Make sure that a correct water supply to the pump is provided.
2. Make sure that water inlet filters are properly clean.
3. Electrical components and wiring, with special emphasis on connections, junction boxes, switches and supply cables should be free from external damage (i.e. exposed and broken wires) and adequately protected against water.
4. High pressure hose should not show apparent external wear and the fittings at both ends should be free from signs of erosion or corrosion.
5. Make sure that all fluids (lubricating oil for pump and engine, cooling water, hydraulic fluids) are at proper levels and in good condition.
6. Make sure the safety guards are in good condition.

The work should stop immediately and the pressure must be released in the event that leakage becomes apparent or if any person becomes aware of a change in condition or any hazard existing or being introduced. Any failure must be promptly reported and then checked personnel.



3.4 General procedures for high pressure gun/lance operation

1. The Operator should take reasonable care for the safety of himself and of other persons who may be affected by his acts or omission at work. His actions should always be governed by his good sense and responsibility.
2. The Operator should wear suitable waterproof protective clothing, having regard to the type of work being undertaken. The clothing set should include adequate hand protection, suitable boots able to ensure proper grip on wet floors, helmet provided with full face shield, waterproof garment providing full cover to the Operator, including his arms.
As most water jets produce noise levels in excess of

90 dB(A) suitable ear protection is advised.

NOTE: *it must be emphasized that whereas protective clothing provides adequate protection against spray and flying particles, it does not constitute complete protection against the direct impact of the water jet. Additional protections in the form of suitable metal shields or barriers may be necessary for certain jetting operation.*

3. In most jetting operations it is an accepted practice to employ a team of Operators consisting of two members at least, in order to provide mutual assistance in case of need and to rotate their duties in case of long and heavy work. While the first Operator holds the gun, the second Operator attends the pump unit, keeping close watch on the first Operator for signs of difficulty or fatigue, and watching the surrounding area for intrusion by other persons or unsafe situations. If required, he will shut off the pressure unit until it is safe to continue.
4. The area in which the work is to proceed should be clear of loose items and debris to prevent tripping and slipping hazards.
5. The water jet should be directed only and always against the workpiece even during preliminary operating tests prior to starting work.
6. Where applicable, proper side shields should be suitable placed to safeguard personnel and equipment against contact with grit or particles removed by the water jet.
7. On no account must the Operator be distracted during operation until the jet has been stopped. Personnel having reason to enter the water jetting area should wait until the jet is stopped and his presence known.
8. Each team member must always be aware of the actions and intentions of other team members in order to prevent any dangerous misunderstanding occurring during jetting operation.
9. The pump unit should not be started and brought up to pressure unless each team member is in his designated position, the nozzle directed to the workpiece and the lance or gun securely held.

3.5 Safety of maintenance

Apart from the working pressure regulation no attempt should be made to adjust any nut, hose, fitting, etc., while that part of the system is under pressure. The pump should be stopped and any pressure in the line released prior to making any adjustments.

1. The high pressure water unit should be maintained in accordance with the Manufacturer's instructions.
2. The unit should be maintained only by competent personnel
3. Service and maintenance should be carried out with proper tools in order to prevent any damage on high pressure connections and fittings.
4. Use of other than original spar parts is strictly forbidden.

4. PUMP IDENTIFICATION

Each pump is fitted with a rating plate (see Fig. 1) containing the following information:

2. pump model and version
3. serial number
4. max RPM
5. max operating pressure (bar)
6. oil capacity (ltr) and oil specification
7. max flow rate (l/min)

Pump model, pump version and serial number should be specified when ordering spare parts. Should the pump be modified (i.e by changing the original version) than any change should be mentioned on the rating plate for future reference.

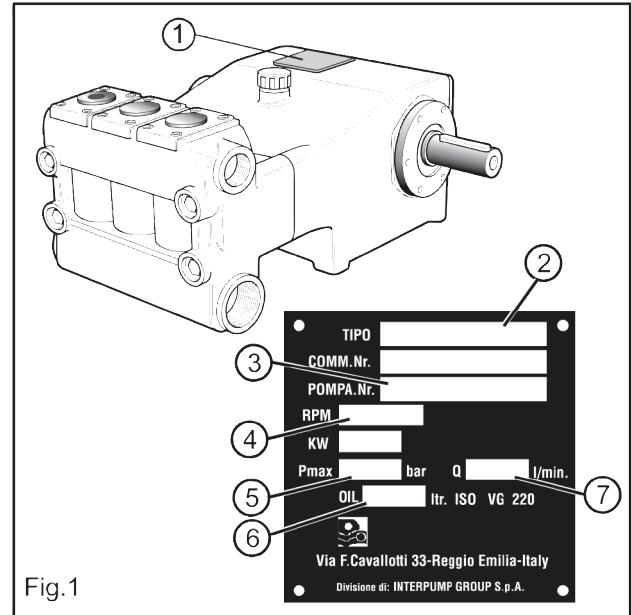

Fig.1

5. TECHNICAL FEATURES

MODEL	RPM	FLOW RATE		PRESSURE		POWER	
		GPM	l/min	PSI	Bar	Hp	kW
KL30	1000	22.2	84	2600	500	39.6	29.1
KL33	1000	27.0	102	2150	400	39.8	29.2
KL36	1000	32.2	122	1750	320	37.4	27.5
KL40	850	33.8	128	1600	250	36.6	26.9
KL50	800	40.1	152	1450	180	39.6	29.1
KL50	700	43.3	164	1150		34.0	25.0

6. DIMENSIONS AND WEIGHT

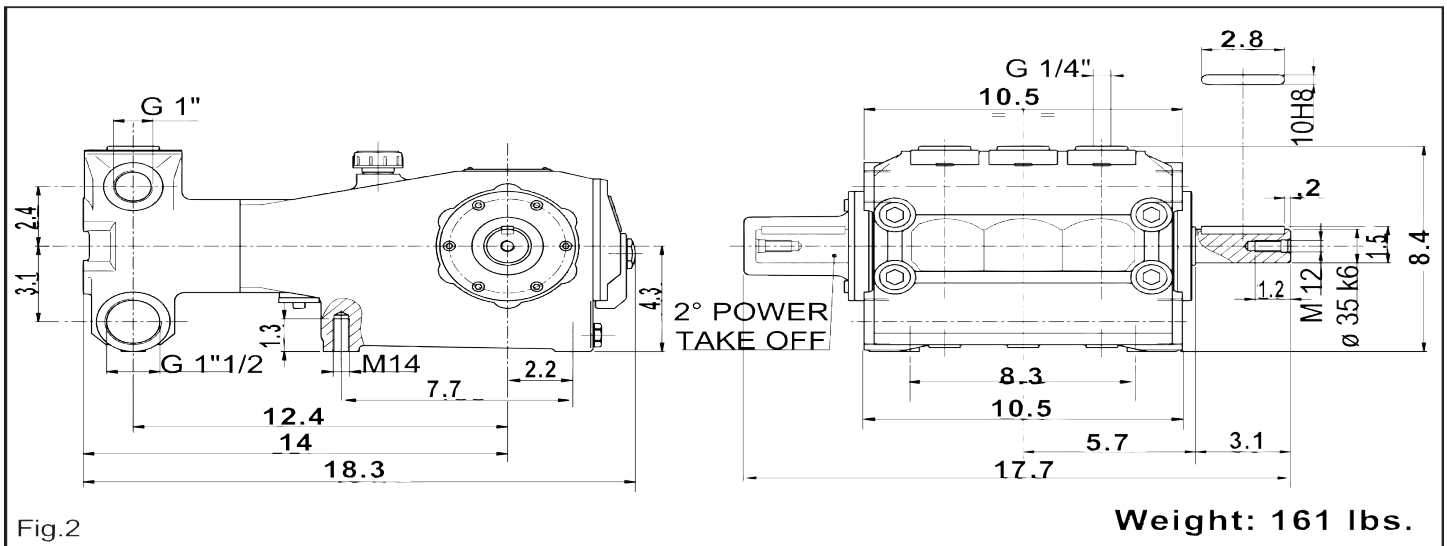

Fig.2

Weight: 161 lbs.

7. GENERAL INFORMATION ABOUT PUMP USE



The KL pump has been designed to pump fresh filtered water at room temperature. KLZ-N special stainless steel versions are also available for critical fluids.

7.1 Water temperature

Water temperature is critical for the pump life, the higher it is, the more likely it is to create cavitation, resulting in premature seal and valve failures.



Below is the temperature chart and relevant limitations:

<104°F	Water is considered to be at room temperature.
from 104°F to 140°F	<p>feed the plunger pump with a centrifugal pump supplying at least twice the plunger pump volume at 30 to 45 PSI</p> <p>reduce pump rated RPM by 30% to 50%</p> <p>Make sure the crankshaft turns as indicated by the arrows located neat the drive shaft projection</p>
>140°C	standard pump not suitable, contact our Customer service Department

7.2 Max flow and pressure ratings

The performance data indicated in the catalog and on the rating plate refer to the maximum performance of the pump. The use of the pump below the rated performances does not allow the drop in power absorbed to be balanced by altering the pressure or volume of the pump above its maximum value.

7.3 Lowest operating RPM

The lowest operating speed for all KL's (all versions) is 500 RPM

8. CONNECTIONS AND PLUGS

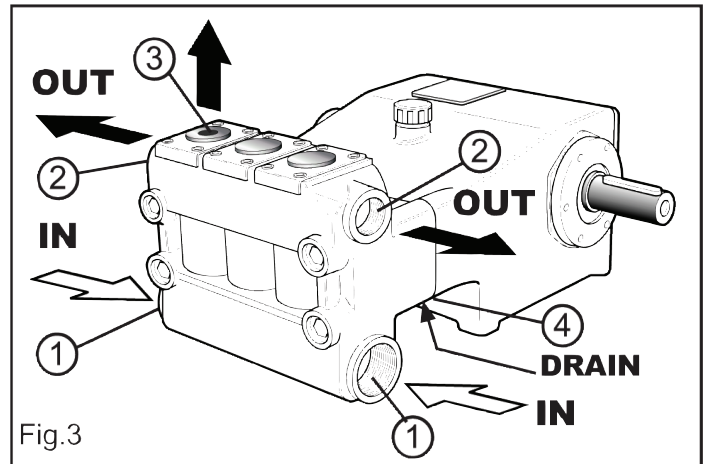

KL pumps are provided with (Fig. 3):

- 1 - 2 x suction ports IN Ø G 1-1/2"
Suction line connection to any of the two inlet ports is acceptable, the port not being used should be sealed with the correct plug.
- 2 - 2 x outlet ports OUT Ø G 1".
- 3 - 1 outlet port Ø G 1/4" (pressure gauge)
- 4 - 1 hole DRAIN provided underneath the crankcase and designed to drain out the water leakage of the pressure packings. **This hole must always be left open (see paragraph 10.3, Fig 7, page 9).**

9. PUMP INSTALLATION

9.1 Positioning

The pump should be installed flat on a rigid base by means of the four M12 threaded feet. The base should be rigid enough to avoid any misalignment or flexing of the pump/transmission coupling axis due to the torque involved during operation.

On no account should the pump be installed in such a way its fluid end rests on the base where the pump is mounted. The fluid end should be left free and not subjected to any force. (Fig 4).

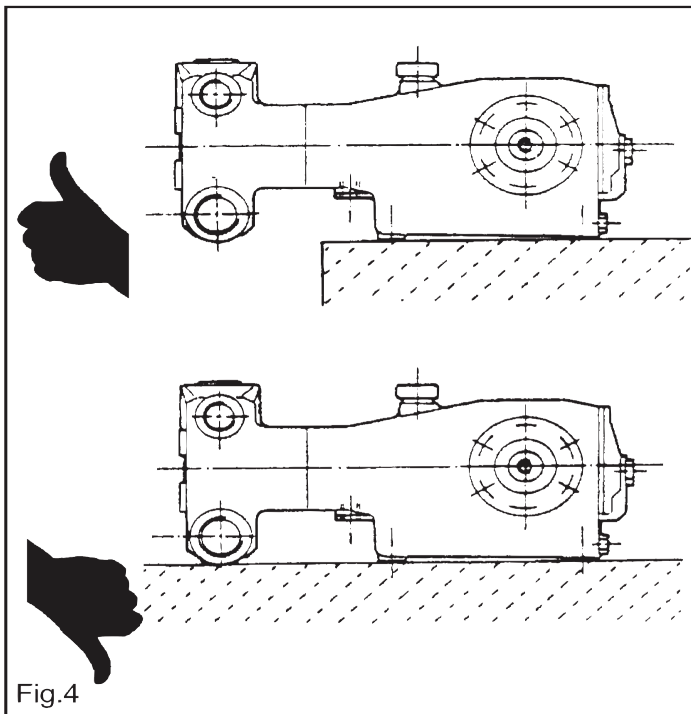

9.2 Direction of rotation

Fig. 5 shows the correct direction of rotation looking at the pump from the fluid end side. Two arrows stamped on the crankcase nearby the crankshaft provide the information as well.

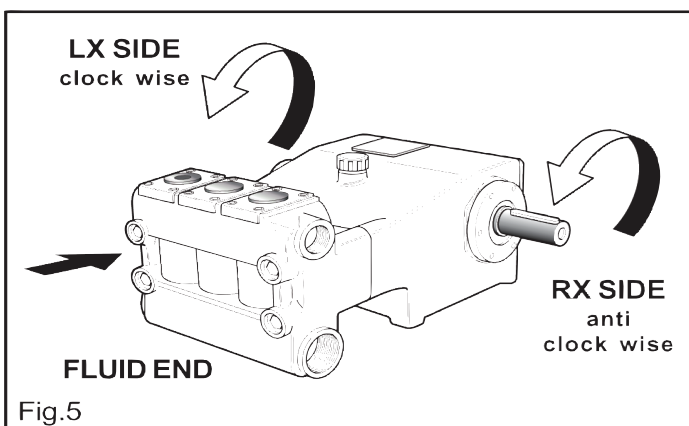

9.3 Water connections

In order to isolate the high pressure equipment from the pump vibrations it is suggested, where applicable, to use flexible hoses for both suction and delivery lines at least for the first length. The flexible suction hose must be rigid enough to prevent it from collapsing during the suction stroke, when a partial vacuum may occur.

9.4 Suction line

Plunger pumps are not self priming therefore a positive suction head should always be provided. Information for the correct suction line:

1. Internal diameter should be at least 3", in any point, possibly larger depending on the drop in pressure due to the length and shape of the line.
2. Should be as straight as possible minimizing changes in size and direction and positioned in such a way to allow air pockets and bubbles to escape.
3. Should be perfectly airtight.
4. Should be completely free from 90° elbows, diameter reductions, counter slopes, "T" connections and should not be connected to other pipelines.
5. Should be positioned in such a way to prevent the pipe emptying after the pump stops.
6. Do not use high pressure flexible hoses for the suction line.
7. Do not use high pressure hydraulic fittings like 90° elbows, high pressure adapters, high pressure 3 or 4 way nipples and so on.
8. Do not install any kind of detergent injector along the suction line.
9. Do not install standing valves, check valves or other kind of one-way valves.
10. Make sure that the feed tank capacity and the water minimum level do not give rise to turbulence at the tank outlet port, which, in turn, might create cavitation at the pump.
11. Do not connect the by-pass line from the valve directly to the pump suction line.
12. The water flow from the valve should be directed back in the tank. Make sure that the by-pass and tank feeding flows to not give rise to turbulence at the tank outlet port, which, in turn, might create cavitation at the pump. Proper baffle plates should be provided inside the tank.
13. Before connecting the suction line to the pump inlet port make sure the pipe is perfectly clean inside.

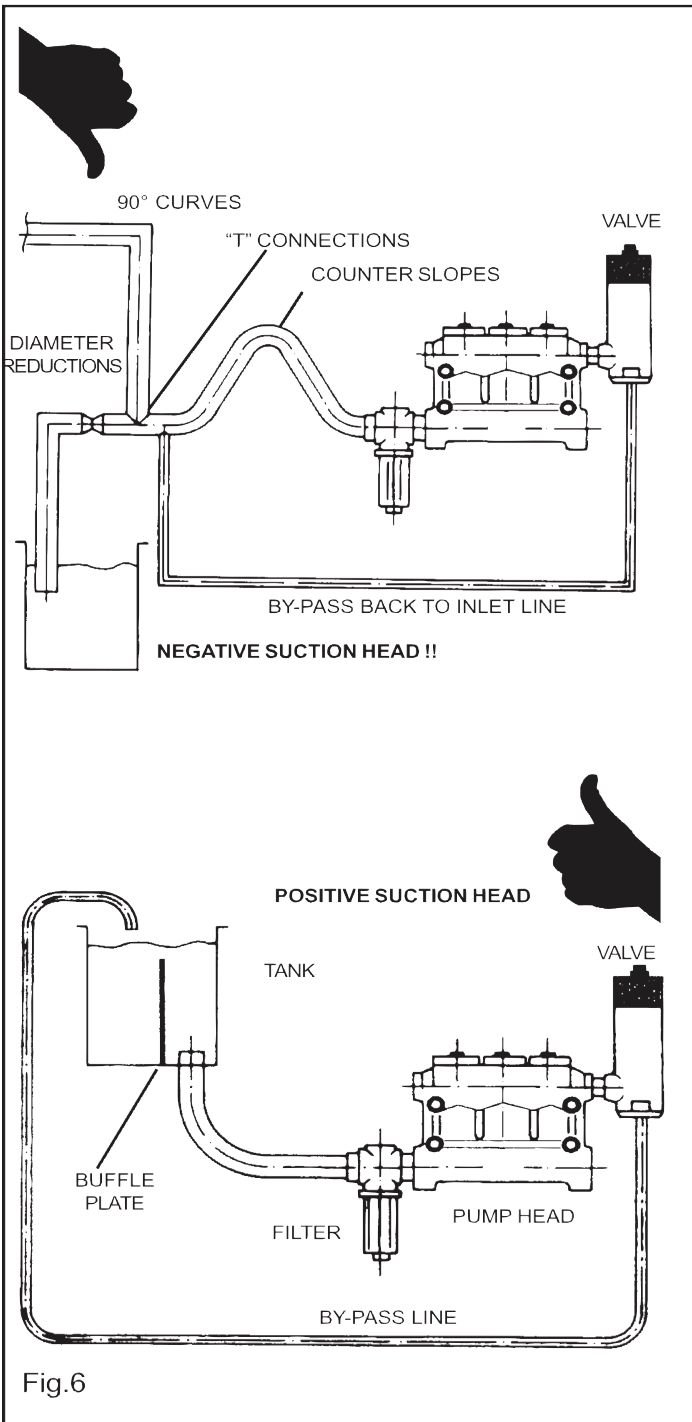

9.5 Filtration

All pumps require a suitable filter. The filter should be installed as close as possible to the pump, should allow easy inspection and have the following characteristics:

1. The filter capacity should be at least three times the rated pump volume.
2. Filter port diameters should not be smaller than the pump inlet ports.
3. Filtration degree in between 50 and 80 mesh (360 to 200 microns).

IMPORTANT NOTE: In order to properly safeguard the pump it is very important to plan cleaning of the filter with a frequency depending on the water quality, filtration degree and number of hours of each application.

9.6 Delivery line

For a correct delivery line comply with the following instructions:

1. The first length of delivery hose should be flexible in order to isolate the pump vibrations from the rest of the system.
2. Use only high pressure hoses and fittings able to guarantee the largest possible safety margins in any working conditions.
3. A suitable relief valve should be installed in the delivery line.
4. Use glycerine filled pressure gauges, as the most suitable for pulsating loads.
5. When designing the delivery line, take into proper account the unavoidable drop in pressure, due to its length and size.
6. If necessary, the effects of the pump pulsations can be reduced by installing a proper pulsation dampener in the pressure line.

10. START UP AND RUNNING PROCEDURES

10.1 Before start up

Before start up make sure that the following conditions have been complied with:

1. Suction line should be connected: **the pump must never run dry.**
2. Suction line must be perfectly air-tight.
3. Any ON-OFF valve in between the pump and water source should be open and make sure the water gets into the pump freely.
4. Set the pressure line in dump mode in order to let the air in the pump get out easily thus facilitating the pump priming.
5. Make sure all suction/delivery line connections are fully tightened.
6. Joint alignment, belt tightening and PTO shaft inclination tolerances should remain within the values indicated by the transmission Manufacturer.
7. Make sure the oil level is correct.

Note: *in case the pump has not run for a long period of time check the suction and delivery valves for scaling (see paragraph 11.2).*

10.2 Starting up

1. Pump and motor/engine should start offload, set the regulating valve to zero or set the pressure line in dump mode by means of proper dumping devices.
2. When starting the pump up for the first time or after every wiring re-connection check for the proper direction of rotation.
3. Check that the rotating speed does not exceed the rated value.
4. Before putting the pump under pressure let it run for some time until the oil flows freely.
5. Before stopping the pump release the pressure from the system by operating the dump device or by releasing the regulating valve and reduce RPM to a minimum (diesel applications).

Note: *in case of feeding by a centrifugal pump, make sure that the plunger pump start only when the correct inlet pressure is provided.*

10.3 Water leakage

During operation a small amount of water (a few drops a minute) is released from the pump fluid end; this leakage is designed to provide lubrication for the pressure packings. The leakage is drained out of the pump through a hole in the lower cover (Fig. 6). **This hole must always be kept open.**

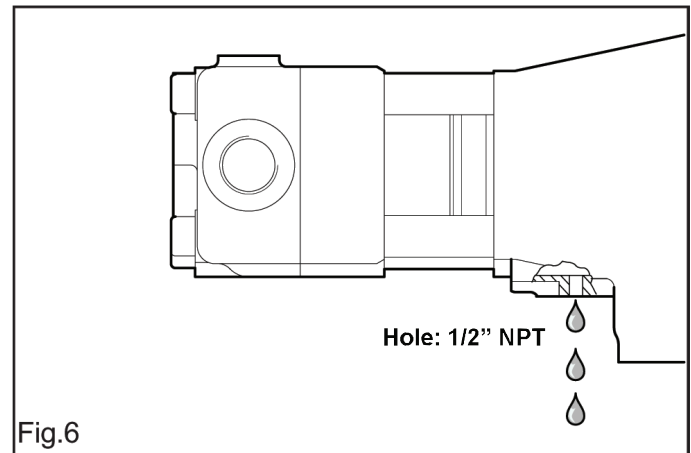

11. MAINTENANCE INSTRUCTIONS



11.1 Crank mechanism maintenance.

Check oil level through the oil level indicator 1, Fig 8 at least on a weekly basis.

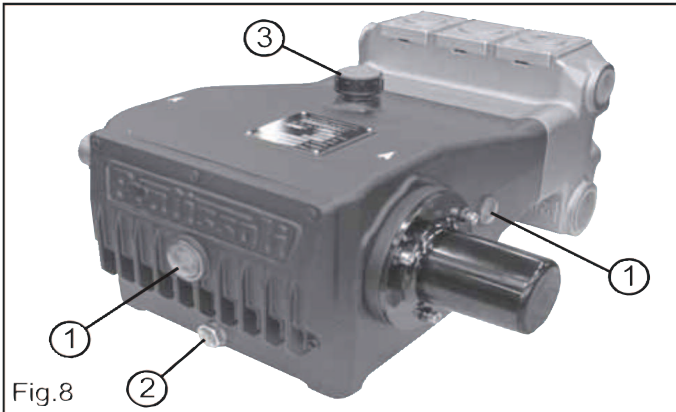

If necessary, top up from the oil plug 3, Fig. 8. Check the oil when cold and change the oil when still hot (pump still at working temperature.). In order to drain the oil from the pump remove the magnetic plug 2, Fig. 8. At every oil change clean the magnetic plug 2, Fig. 8 and check the lower cover of Fig. 6 for grease sediments or deposits.

OIL CHANGES	Hours	Qty.	Oil Type
First Change	50	3.1 quarts	ISO 220
Subsequent Changes	500		

Oil should be changed at least once a year.

Recommended oils:

BRAND	TYPE
AGIP	ACER 220
ARAL	MOTANOL HP 220
AVIA	AVILUB RSL 220
BP	ENERGOL HL 220
CASTROL	ALPHA ZN 220
ESSO	NUTO 220
FINA	SOLNA 220
IP	HYDRUS 220
MOBIL	DTE OIL BB
SHELL	TELLUS C 220
TEXACO	REGOL OIL 220
TOTAL	CORTIS 220

11.2 Fluid end maintenance

The fluid end does not require periodical maintenance. Service operations are limited to valve inspection and/or replacement, when necessary. In order to remove the valves:

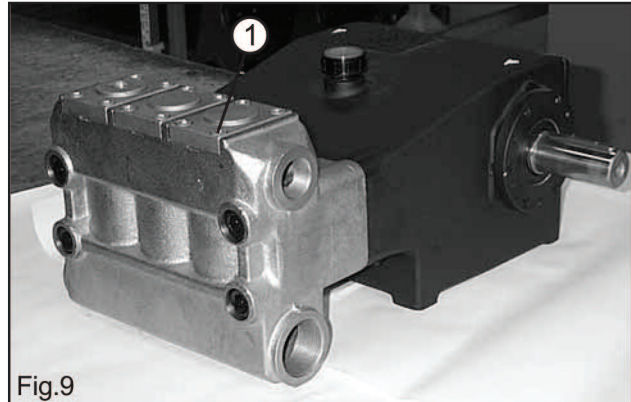

Fig.9

Loosen and remove the valve cover screws (Fig. 9).

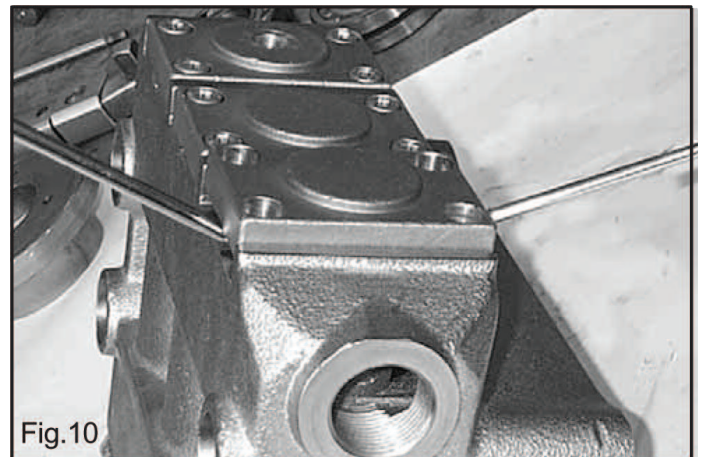
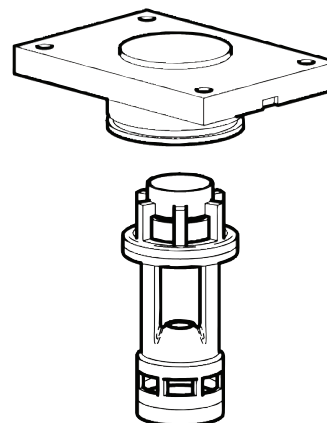

Fig.10

In order to facilitate pulling the valves out, marked notches in the valve cover are provided (Fig 10).



Valve components of each valve unit are pressed together in one single block and therefore they can be easily replaced and installed back in place. Separating the various components of the valve unit is carried out by means of simple tools as shown in Fig. 11, 12, 13 on page 11).

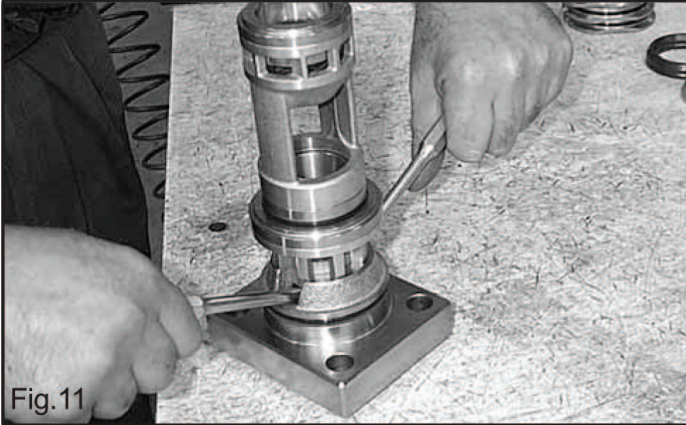

Fig.11

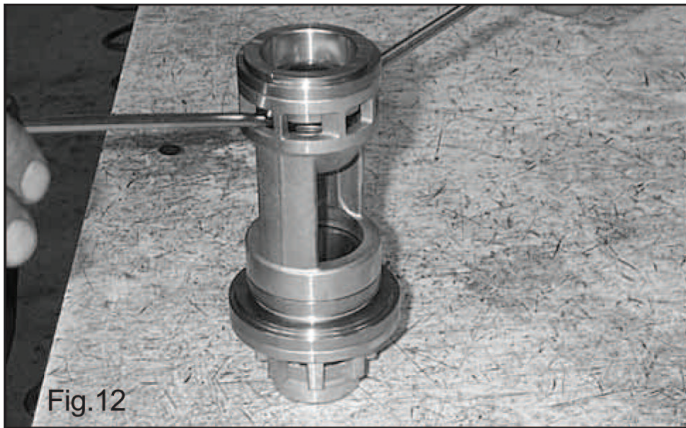

Fig.12

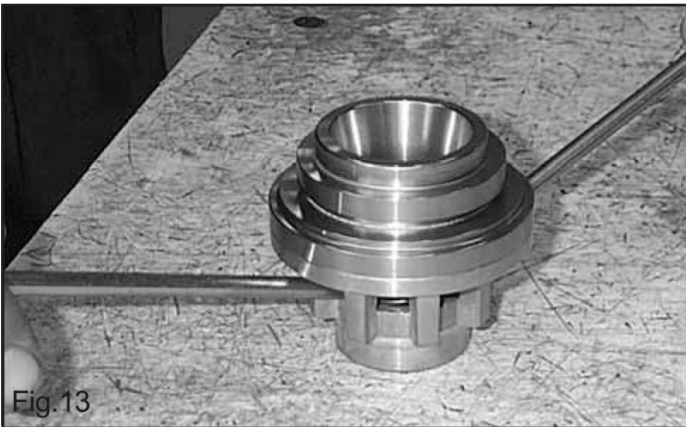

Fig.13

Check the valve components for wear and replace where necessary. **Every time valves are inspected, all o-rings and valve covers should be replaced.**



Reassemble the valve units and fit them back in the fluid end. Valve cover screws should be tightened with a torque wrench set for 25.3 ft. lbs.



IMPORTANT:
BEFORE REPOSITIONING THE VALVE UNITS CLEAN AND PERFECTLY DRY ALL VALVE HOUSINGS INSIDE THE FLUID END (SEE ARROWS).

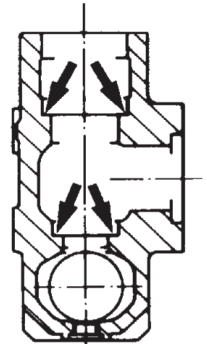

Fig.14

Should excessive scaling inside the fluid end hinder the valve extraction open one of the two lateral inlet ports, remove the three plugs, Fig. 15, insert our special tool p/n F200000040 (or a corresponding one) and push the valve unit out as shown in Fig. 15.

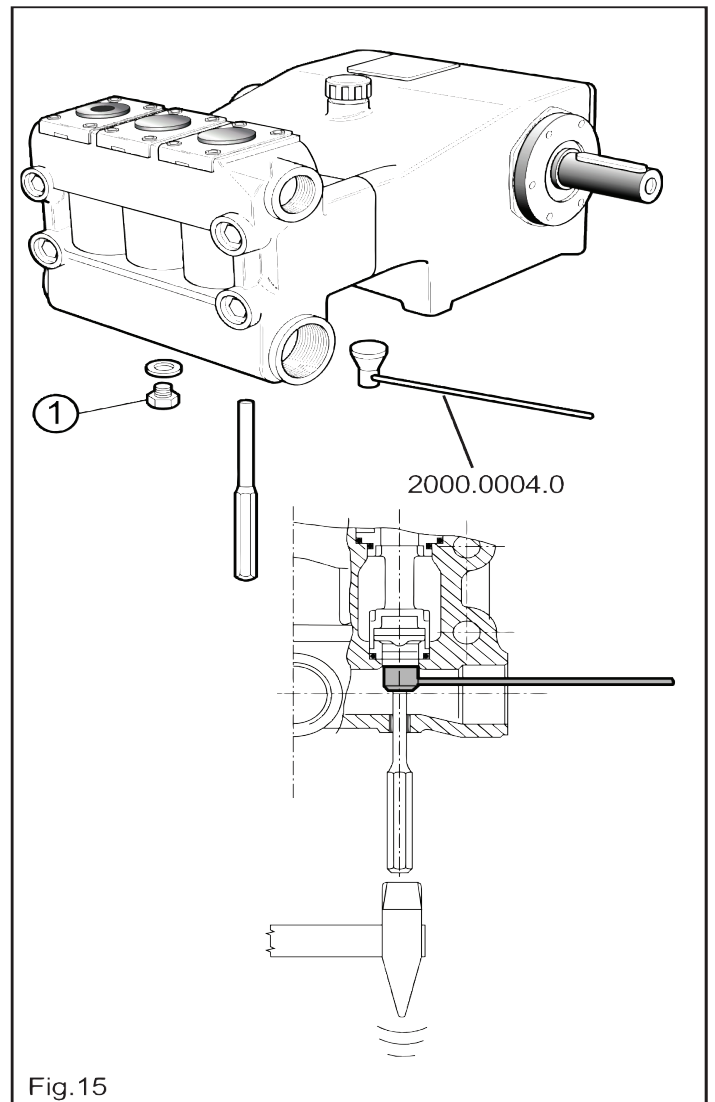
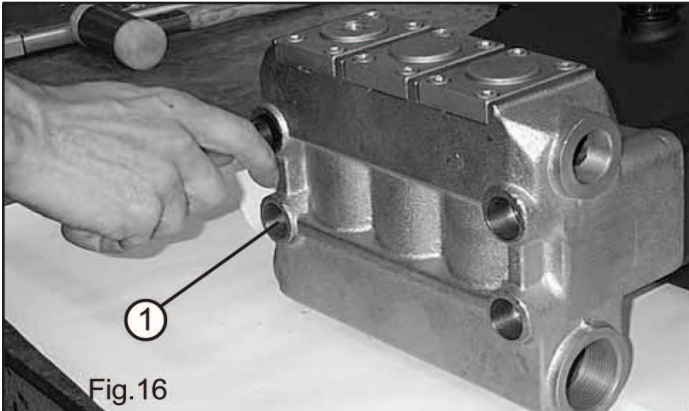

Fig.15

11.3 Pumping unit maintenance

The only maintenance operation required for the pumping unit is to periodically check the amount of water drained out by the pump through the hole provided in the lower cover (Fig 6, page 9). It clearly shows the pressure packing state of wear; replace them if water dripping becomes continuous and not intermittent.



In order to check for the pumping units, separate the complete fluid end from the pump by removing the four bolts (1, Fig. 16).

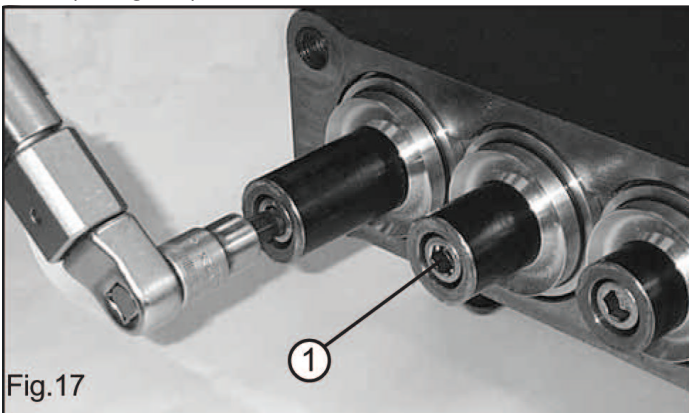

Remove the plunger screws (1, Fig. 17).



Once fluid end and plunger screws are removed, cylinders and plungers are free to slide out without any other operation (Fig. 18). Check the state of wear of the parts and replace where necessary. **Every o-ring should be replaced at every inspection.**

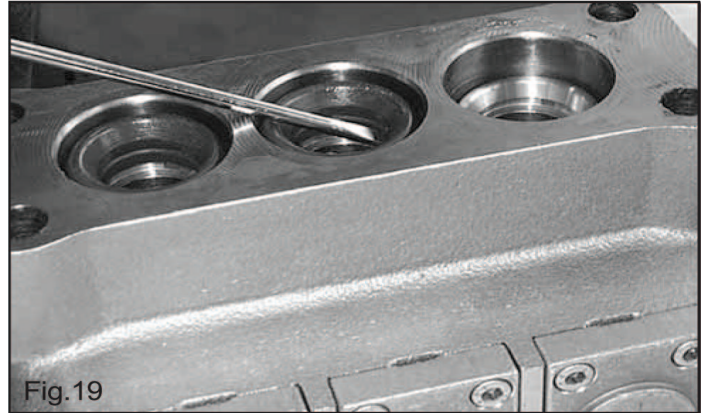

Replace pressure packings every time the fluid end is disassembled. The operation can be carried out with simple tools or by hand as well (Fig 19).

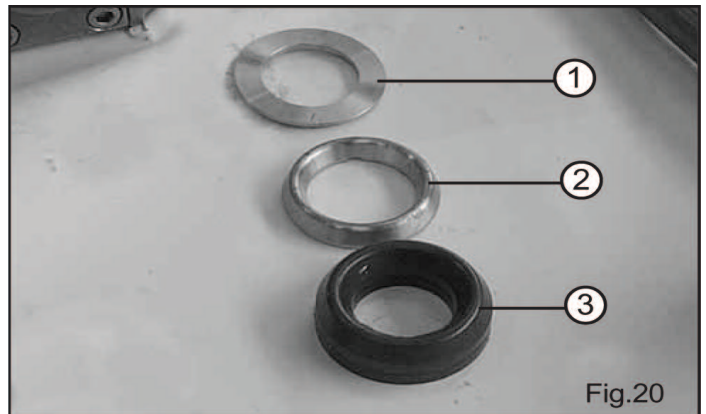

When reassembling make sure of the correct order of the entire package made up of the following components (Fig. 20):

1. Spacer
2. Packing ring
3. Pressure packing (two pieces)

A little bit of grease helps when sliding the pressure packings into the fluid end. Fit the plunger back in place **without tightening the plunger screw**. Fit the cylinder back in place and then tighten the plunger screw with a torque wrench set for 50.6 ft. lbs.



Fit the fluid end back in place and tighten the four bolts (1, Fig 16) with a torque wrench set for 133.8 ft. lbs.

12. SCREW CALIBRATION



Screw calibration is to be carried out by means of a torque wrench only:

DESCRIPTION	Ft. Lbs.	N-m	Kgm.
Valve cover screws	25.3	34.3	3.5
Head Bolts	133.8	181.4	18.5
Plunger bolts	50.6	68.6	7
Connecting Rod Screws	28.9	39.2	4

13. MAINTENANCE TOOLS



The following tools are designed to facilitate mounting and dismounting operations of some pump components:

- For disassembling:
- piston guide oil seal extractor F200000140
 - valve unit extractor F200000040
- For assembling:
- piston guide oil seal F200000030

14. PUMP STOPPED FOR LONG TIME



Before starting the pump for the very first time after a long period from the date of shipment check for the correct oil level, check the valves as indicated in chapter 11 and then comply with the starting procedures indicated in chapter 10. When a long inactivity is scheduled drain the entire suction and delivery line and then run the pump dry **only for a few seconds** in order to drain out the water collected inside the fluid end.

15. PRECAUTIONS AGAINST FREEZING



In the risk of freezing the following precautions should be taken:

- After use drain the entire suction and delivery lines (filter included) by means of discharging devices, provided and positioned specifically for this purpose along the lowest point of the lines.
 - Run the pump only for a few seconds in order to drain the water collected inside the fluid end.
- Or when applicable
- Add a recommended amount of anti-freeze into the water tank and run the pump until the anti-freeze works all through the system.



If a pump is frozen or appears frozen ON NO ACCOUNT SHOULD THE PUMP BE OPERATED until the entire system has been thawed out.

16. EXPLODED VIEW AND PARTS LIST

KL

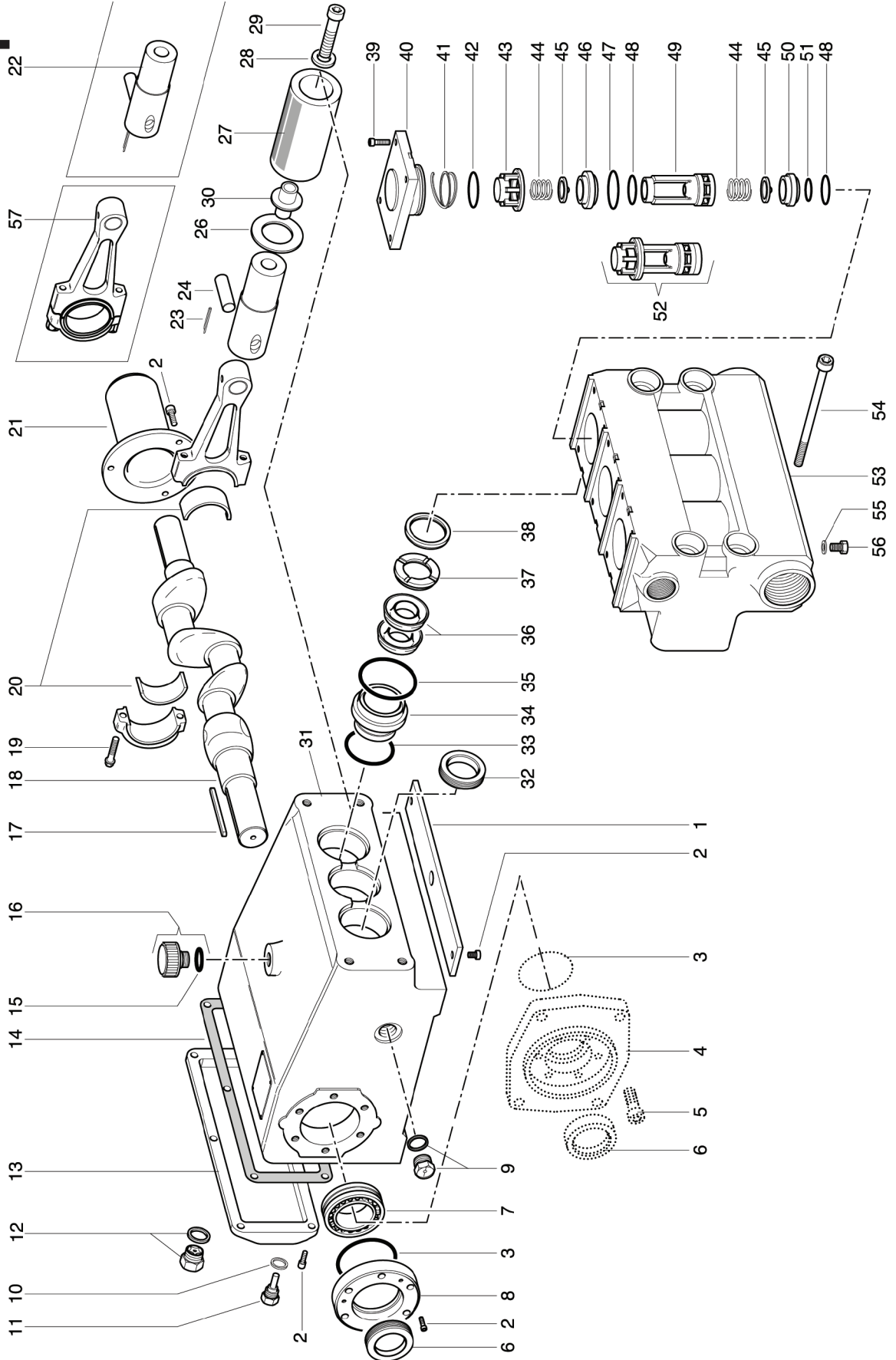

Item	Part #	Description	QTY.
1	F040000130	Lower cover	1
2	F871115153	Screw, M 6 x 16	17-23
3	F881013100	O-ring Ø 80 x 2.5	2
4	F010100050	Hydraulic motor flange (Type A)	1
	F010100040	Hydraulic motor flange (Type B)	1
5	F871125154	Screw, M 10 x 30	6
6	F881080014	Oil seal Ø 40 x 60 x 10	2
7	F811110002	Bearing	2
8	F063400100	Bearing cover	1-2
9	F801053002	Oil level indicator G 1/2"	1
10	F872043001	Aluminum washer Ø 3/8"	1
11	F801057001	Magnetic plug G 3/8"	1
12	F801053003	Oil level indicator G 3/4"	1
13	F063400120	Back cover	1
14	F080600000	Back cover gasket	1
15	F881011153	O-ring Ø 18 x 3	1
16	F801054002	Oil filling plug G 1/2"	1
17	F071000030	Key	1
18	F050000030	Crankshaft	1
19	F871350002	Connecting rod screw	6
20	F812000002	Brass bearing	3
21	F040400010	Crankshaft end cap	1
22	F250001020	Plunger guide assembly	3
23	F872138010	Retainer pin Ø 2.5 x 22	3
24	F071000020	Wrist pin Ø 20	3
26	F041200000	Wiper	3
27	F024200090	Plunger KL30	3
	F024200100	Plunger KL33	3
	F024200110	Plunger KL36	3
	F024200120	Plunger KL40	3
	F024200130	Plunger KL45	3
	F024200140	Plunger KL50	3
28	F872040003	Washer Ø 12 Spec.	3
29	F871131518	Screw M12 x 110 inox KL30-33-26-40	3
	F871131509	Screw M 12 x 60 inox KL45-50	3
31	F060100120	Crankcase	1
	F060100130	Crankcase, hydraulic	1
32	F881081002	Oil Seal Ø 38 x 52 x 7 Spec.	3
33	F881010012	O-ring Ø 50.52 x 1.78	3
34	F022300090	Packing support KL30	3
	F022300100	Packing support KL33	3
	F022300110	Packing support KL36	3
	F022300120	Packing support KL40	3
	F022300130	Packing support KL45	3
	F022300140	Packing support KL50	3
35	F881010011	O-ring Ø 47.34 x 1.78 KL30	3
	F881010012	O-ring Ø 50.52 x 1.78 KL33-36-40	3
	F881010013	O-ring Ø 56.87 x 1.78 KL45-50	3
36	F881020008	Pressure packing KL30	6
	F881020009	Pressure packing KL33	6
	F881020010	Pressure packing KL36	6
	F881020011	Pressure packing KL40	6
	F881020012	Pressure packing KL45	6
	F881020013	Pressure packing KL50	

Item	Part #	Description	QTY.
37	F031200070	Packing ring KL30	3
	F031200080	Packing ring KL33	3
	F031200090	Packing ring KL36	3
	F031200100	Packing ring KL40	3
	F031200110	Packing ring KL45	3
38	F031300000	Spacer KL30	3
	F031300010	Spacer KL33	3
	F031300020	Spacer KL36-40	3
	F031300030	Spacer KL45-50	3
39	F871121954	Screw M 8 x 25 Spec.	12
40	F063300020	Valve cover	2
	F063300040	Valve cover G 1/4"	1
41	F881112001	Anti-extrusion ring	3
42	F881010214	O-ring Ø 49.21 x 3.53 Spec.	3
43	F021300010	Delivery valve guide	3
44	F090200020	Valve spring	6
45	F082200020	Valve poppet	6
46	F081200030	Delivery valve seat	3
47	F881011160	O-ring Ø 50.50 x 3 Spec.	3
48	F881011157	O-ring Ø 36 x 3 Spec.	6
49	F021300370	Suction valve guide KL30-33	3
	F021300320	Suction valve guide KL36-40-45-50	3
50	F081200020	Suction valve seat	3
51	F881010010	O-ring Ø 25.12 x 1.78 Spec.	3
52	F208004660	Valve assembly KL30-33	3
	F208004670	Valve assembly KL36-40-45-50	3
53	F064100390	Manifold KL30	1
	F064100130	Manifold KL33	1
	F064100150	Manifold KL36-40	1
	F064100180	Manifold KL45-50	1
54	F871141169	Screw M 16 x 150	4
55	F872043000	Aluminum washer Ø 1/4"	3
56	F084390000	Brass Plug G 1/4"	3
57	F250000050	Connecting rod assembly	3

REPAIR KITS

Item	KL30	KL33	KL36	KL40	KL45	KL50
25-33-35-36 (37)	F1052	F1053	F1054	F1055	F1056	F1054
41-42-47-48-51-55	F1058					
3-6-10-14-15-23-28-32-33-35 36-(37)-41-42-47-48-51-55	F1059	F1060	F1061	F1062	F1063	F1064

KLZ/N

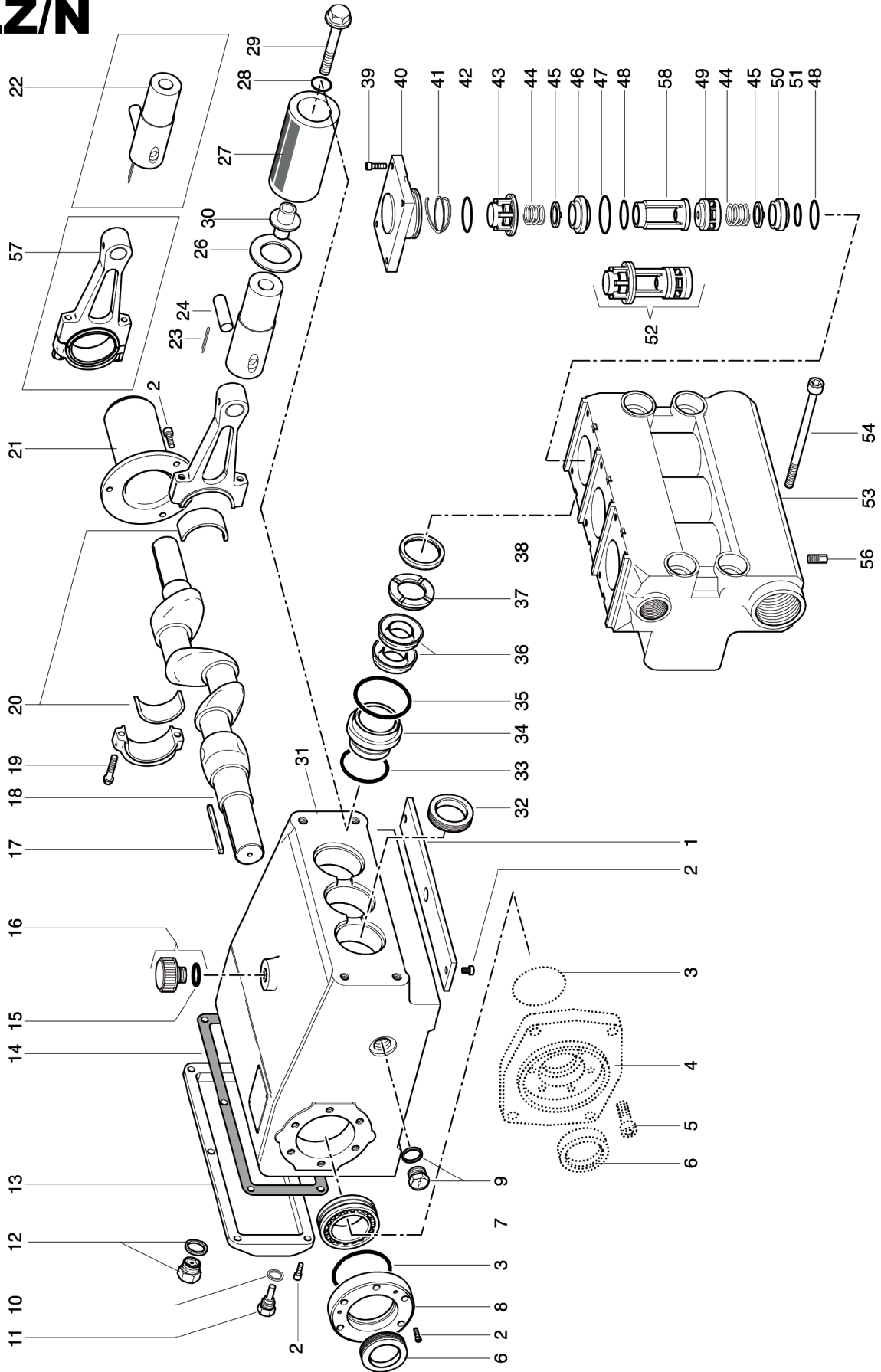

Item	Part #	Description	QTY.
1	F040000130	Lower cover	1
2	F871115603	Screw M 6 x 16 inox	17-23
3	F881013100	O-ring Ø 80 x 2.5	2
4	F010100050	Hydraulic motor flange (Type A)	1
	F010100040	Hydraulic motor flange (Type B)	1
5	F871125606	Screw M 10 x 30 inox	6
6	F881080014	Oil seal Ø 40 x 60 x 10	2
7	F811110002	Bearing	2
8	F063400680	Bearing cover	1-2
9	F801053002	Oil level indicator G 1/2"	1
10	680079	Washer Ø 3/8" nickel	1
11	F801057011	Magnetic plug G 3/8"	1
12	F801053003	Oil level indicator G 3/4"	1
13	F063400670	Back cover	1
14	F080600000	Back cover gasket	1
15	F881011153	O-ring Ø 18 x 3	1
16	F801054002	Oil filling plug G 1/2"	1
17	F071000030	Key	1
18	F050000030	Crankshaft	1
19	F871350002	Connecting rod screw	6
20	F812000002	Brass bearing	3
21	F040400010	Crankshaft end cap	1
22	F250001020	Plunger guide assembly	3
23	F872138010	Retainer pin Ø 2.5 x 22	3
24	F071000020	Wrist pin Ø 20	3
26	F041200000	Wiper	3
27	F024201010	Plunger KLZ/N30	3
	F024201020	Plunger KLZ/N33	3
	F024201030	Plunger KLZ/N36	3
	F024201040	Plunger KLZ/N40	3
	F024201050	Plunger KLZ/N45	3
	F024201060	Plunger KLZ/N50	3
28	F881011062	O-ring Ø 14 x 2 Spec.	3
29	F035200150	Plunger screw	3
30	F010200210	Plunger bushing	3
31	F060100120	Crankcase	1
	F060100130	Crankcase hydraulic	1
32	F881081002	Oil seal Ø 38 x 52 x 7 Spec.	3
33	F881010012	O-ring Ø 50.52 x 1.78	3
34	F022300150	Packing support KLZ/N30	3
	F022300160	Packing support KLZ/N33	3
	F022300170	Packing support KLZ/N36	3
	F022300180	Packing support KLZ/N40	3
	F022300190	Packing support KLZ/N45	3
	F022300200	Packing support KLZ/N50	3
35	F881010011	O-ring Ø 47.34 x 1.78 KLZ/N30	3
	F881010012	O-ring Ø 50.52 x 1.78 KLZ/N33-36-40	3
	F881010013	O-ring Ø 56.87 x 1.78 KLZ/N45-50	3
36	F881020008	Pressure packing KLZ/N30	6
	F881020009	Pressure packing KLZ/N33	6
	F881020010	Pressure packing KLZ/N36	6
	F881020011	Pressure packing KLZ/N40	6
	F881020012	Pressure packing KLZ/N45	6
	F881020013	Pressure packing KLZ/N50	3
37	F031200120	Packing ring KLZ/N30	3
	F031200130	Packing ring KLZ/N33	3
	F031200140	Packing ring KLZ/N36	3
	F031200150	Packing ring KLZ/N40	3
	F031200160	Packing ring KLZ/N45	3
	F881025002	Packing ring KLZ/N50	3

Item	Part #	Description	QTY.
38	F031300170	Spacer KLZ/N30	3
	F031300180	Spacer KLZ/N33	3
	F031300190	Spacer KLZ/N36-40	3
	F031300200	Spacer KLZ/N45-50	3
39	F035000060	Screw M 8 x 25 Spec.	12
40	F063200010	Valve cover KLZ/N	3
	F063300090	Valve cover KLA	3
41	F881112001	Anti-extrusion ring	3
42	F881010214	O-ring Ø 49.21 x 3.53 Spec.	3
43	F021200050	Delivery valve guide KLZ/N	3
	F021300270	Delivery valve guide KLA	3
44	F090200020	Valve spring KLZ/N	6
	F090200030	Valve spring KLA	6
45	F082200020	Valve poppet KLZ/N	6
	F082200030	Valve poppet KLA	6
46	F081200030	Delivery valve seat KLZ/N	3
	F081200050	Delivery valve seat KLA	3
47	F881011160	O-ring Ø 50.50 x 3 Spec	3
48	F881011157	O-ring Ø 36 x 3 Spec.	6
49	F021200030	Suction valve guide KLZ/N	3
	F021300250	Suction valve guide KLA	3
50	F081200020	Suction valve seat KLZ/N	3
	F081200040	Suction valve seat KLA	3
51	F881010010	O-ring Ø 25.12 x 1.78 Spec.	3
52	F208005930	Valve assembly KLZ30-33	3
	F208006470	Valve assembly KLA30-33	3
	F208006770	Valve assembly KLN30-33	3
	F208005940	Valve assembly KLZ36-40-45-50	3
	F208006480	Valve assembly KLA36-40-45-50	3
	F028006780	Valve assembly KLN36-40-45-50	3
53	F064200090	Manifold KLZ/N30	1
	F064300090	Manifold KLA30	1
	F064200110	Manifold KLZ/N33	1
	F064300100	Manifold KLA33	1
	F064200120	Manifold KLZ/N36-40	1
	F064300010	Manifold KLA36-40	1
	F064200140	Manifold KLZ/N45-50	1
	F064300030	Manifold KLA45-50	1
54	F035000140	Screw M 16 x 150 Spec.	4
56	F084200000	Tapered plug G 3/8" inox	3
57	F250000050	Connecting rod assembly	3
58	F070200000	Valve spacer KLZ/N30-33	3
	F070300040	Valve spacer KLA30-33	3
	F070200020	Valve spacer KLZ/N36-40-45-6-50	3
	F070300060	Valve spacer KLA36-40-45-50	

REPAIR KITS

Item	KLZ/N/A30	KLZ/N/A33	KLZ/N/A36	KLZ/N/A40	KLZ/N/A45	KLZ/N/A50
28-33-35-36-(37)	F1070	F1071	F1072	F1073	F1074	F1075
41-42-47-48-51	F1076					
3-6-10-14-15-23-28-32-33 35-36-(37)-41-42-47-48-51	F1077	F1048	F1079	F1080	F1081	F1082

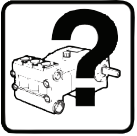

17. TROUBLE SHOOTING



THE PUMP DOES NOT PRODUCE ANY NOISE: the pump is not primed and is running dry!

- No water in the inlet line
- The valves are blocked
- The pressure line is closed and does not allow the air to get out the fluid end.



INSUFFICIENT PUMP PRESSURE:

- The nozzle is (or has become) too large.
- RPM are less than rated
- Excessive leakage from pressure packings
- Excessive amount of water by-passed by the pressure regulating valve or faulty valve operation.
- Worn out valves.



THE PUMP KNOCKS:

- Air suction.
- Insufficient feeding:
 - bends, elbows and fittings along the suction line throttle the amount of water which passed through.
 - too small inlet filter.
 - dirty inlet filter.
 - the feeding pump, where provided is not of the suitable type or provides insufficient pressure or volume.
- The pump is not primed due to insufficient feeding or the delivery line is closed during start up.
- The pump is not primed because some valves are stuck (i.e pump inactivity for long time).
- Jammed or worn out valves.
- Worn out pressure packings.
- The pressure regulating valve does not work properly.
- Clearance in the drive system.
- RPM are higher than rated.

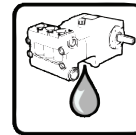

EXCESSIVE WATER LEAKAGE FROM THE PUMP:

- Pressure packing are excessively worn out (due to normal wear or excessive cavitation).
- Worn out plungers

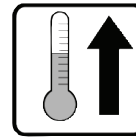

OVERHEATED PUMP:

- The direction of rotation is not correct.
- Pump is overloaded (pressure or RPM over the rated values).
- The oil level is too low or the oil is not of a suitable type or fully used
- Water in the oil
- Excessive belt tension or incorrect alignment of the joint (where provided).
- Excessive inclination of the pump during operation.



THE PUMP DOES NOT DELIVER THE RATED VOLUME:

- Insufficient feeding (due to the cause listed above).
- RPM are less than rated.
- Excessive amount of water by-passed by the pressure regulating valve.
- Worn out valves
- Excessive leakage from pressure packings

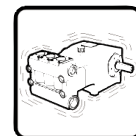

PIPE VIBRATIONS OR KNOCKING:

- Air suction.
- The pressure regulating valve does not work properly.
- The by-pass line is undersized.
- Jammed up valves.
- Drive transmission motion is irregular.

MAINTENANCE LOG

HOURS & DATE

OIL CHANGE							
GREASE							
PACKING REPLACEMENT							
PLUNGER REPLACEMENT							
VALVE REPLACEMENT							



GP Companies, Inc.
1174 Northland Drive
Mendota Heights, MN 55120
Phone: 651.686.2199 Fax: 800.535.1745
www.generalpump.com email: sales@gpcompanies.com

Ref 300563 Rev.C
08/07